

Duracarb Grooving Line New Product News

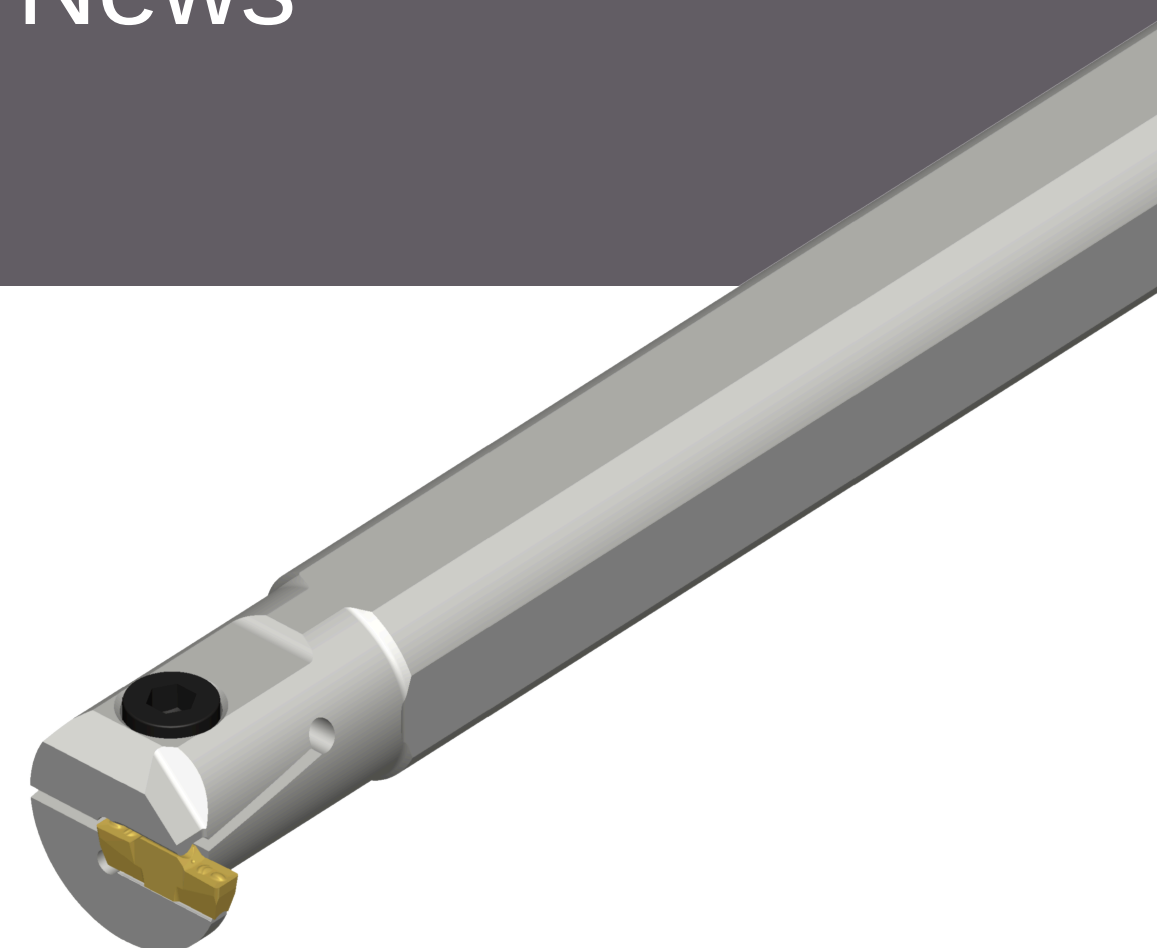

D-Cut holder for Internal Operations

Smart solution for Internal grooving and groove turning

With D-Cut inserts proving themselves as the most economical grooving solutions and with a large number of customers having made the smart choice, Duracarb is pleased to expand our D-Cut program with holders for Internal grooving and groove turning operations. The D-Cut internal holders are designed using the same secure insert clamping mechanism as the external D-Cut holders in order to ensure maximum rigidity and guarantee the best economy.

Feature highlights:

- Strong and secure insert clamping
- For D-Cut inserts 3 & 4
- From Dmin 23
- Shanks 20 & 25

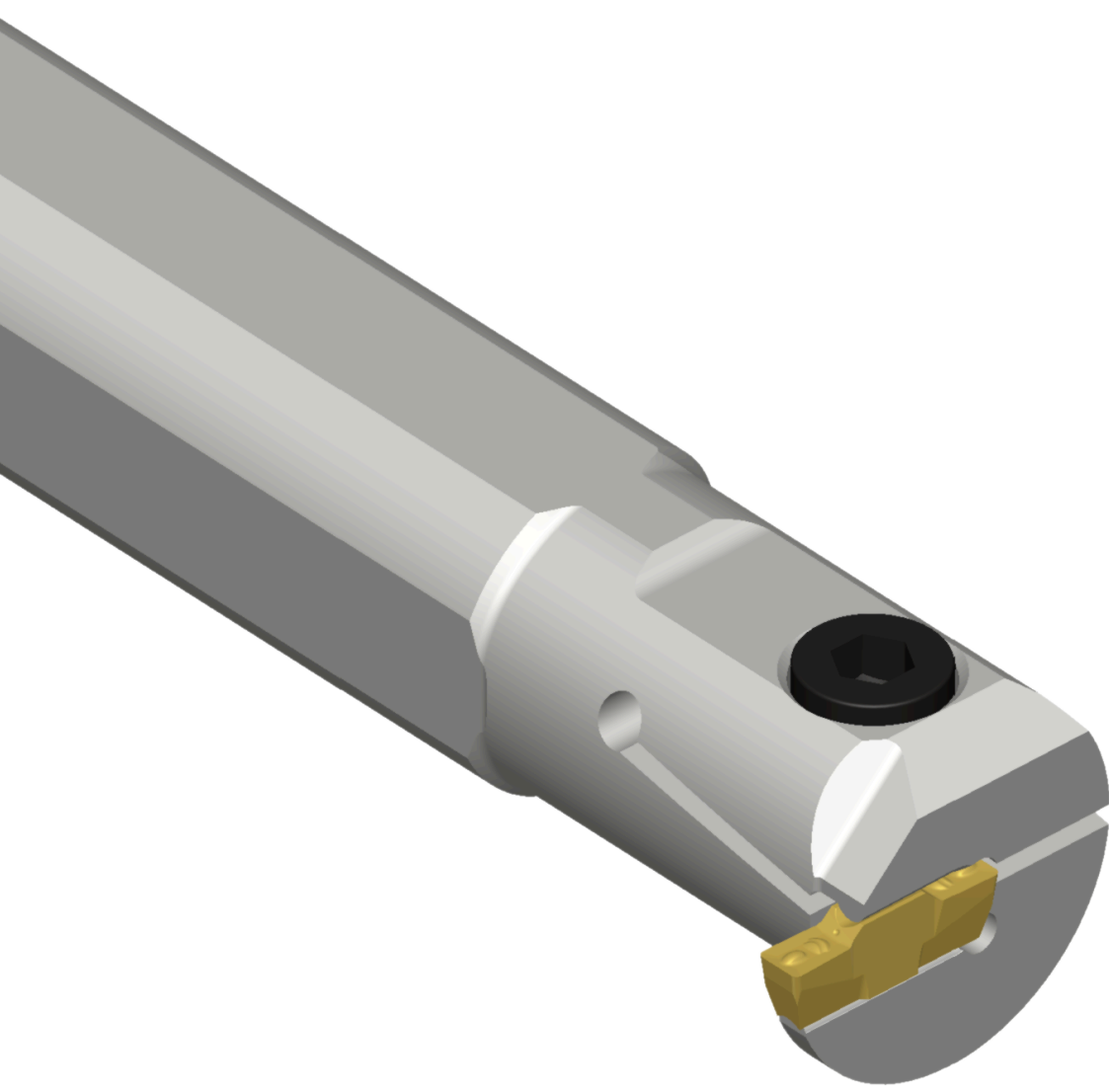

Duracarb Grooving Line New Product News

D-Cut Holder

Internal grooving and groove turn holder

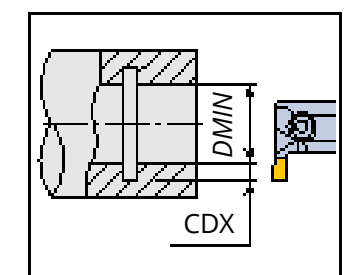
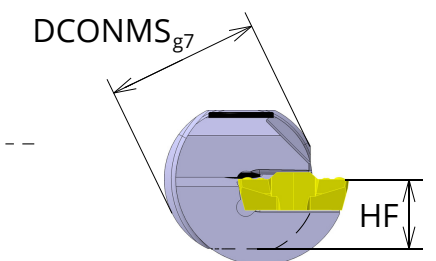
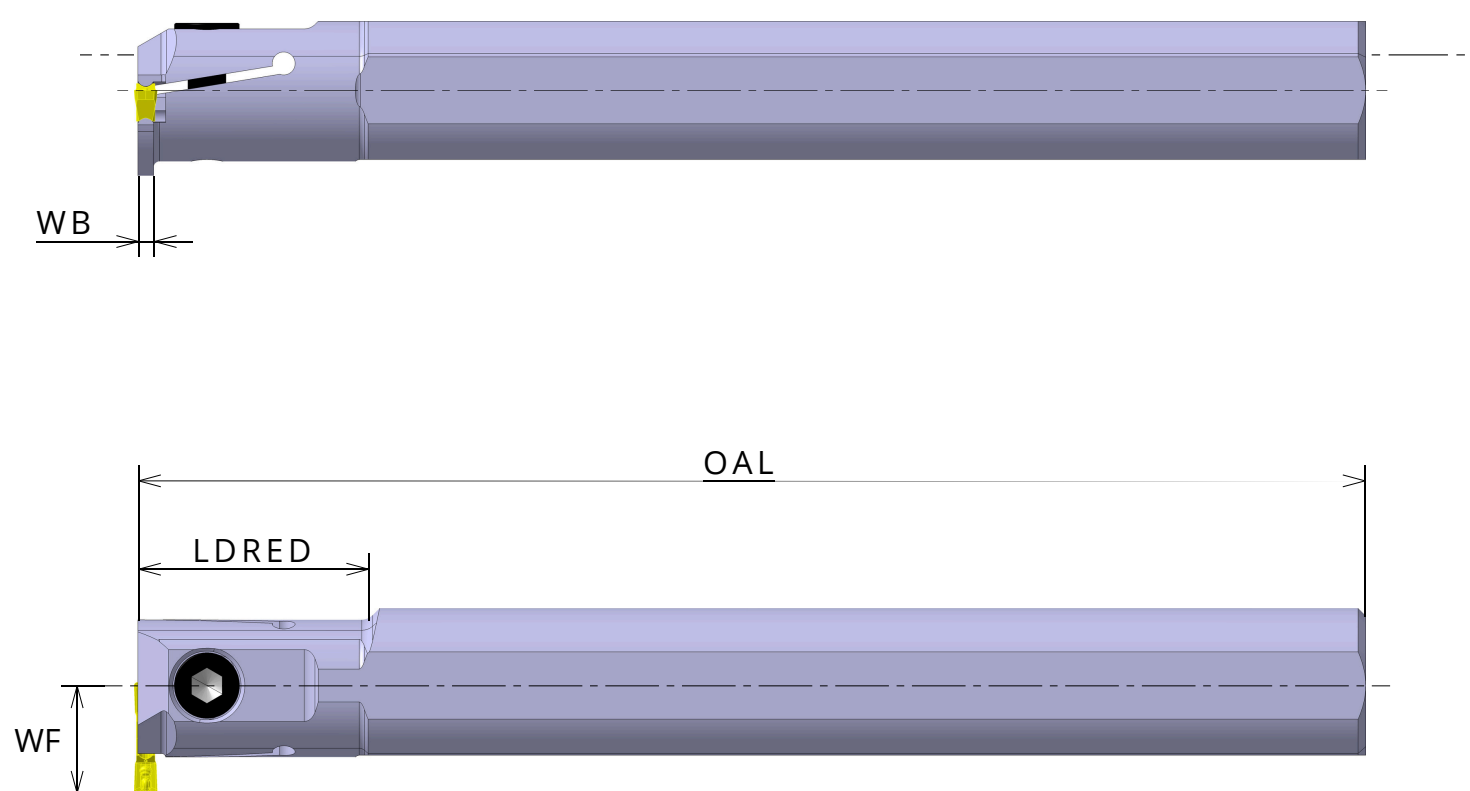
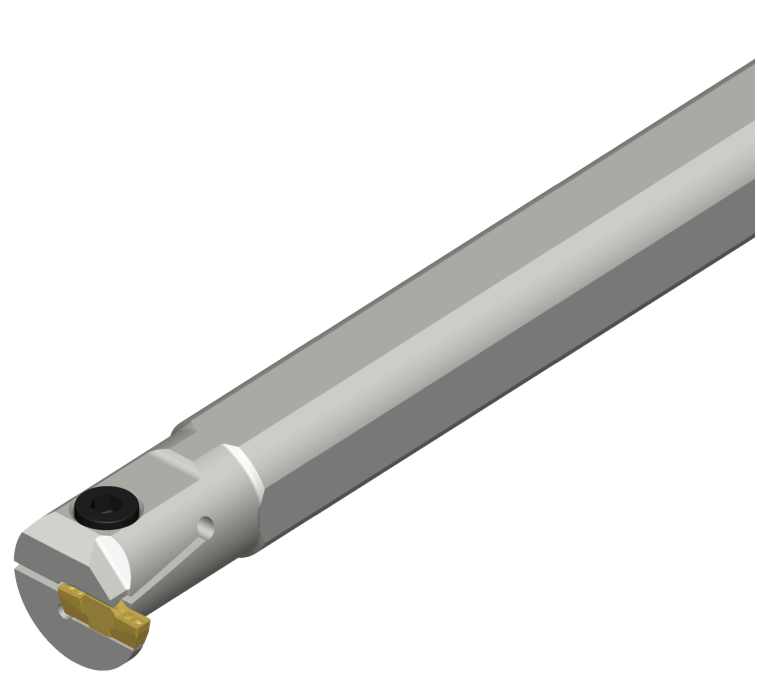
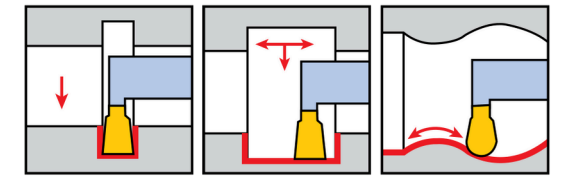

Right hand shown

Designation		Insert seat size	Dimension (mm)							
			DCONMS	OAL	LDRED	WF	HF	WB	CDX	DMIN
DCIR/L	20T04-3	3	20	160	30	15.8	9.0	2.1	4	23
	25T05-3	3	25	200	35	17.5	11.5	2.1	5	23
	20T04-4	4	20	160	30	15.8	9.0	2.9	4	23
	25T05-4	4	25	200	35	17.5	11.5	2.9	5	23

Minimum Diameter

Machining	Size (mm)	Min. dia. (mm)	
		DDGI	DDG/DDDL/ DDM
Internal Grooving <small>Min. dia. of internal machining</small>	3	23	105
	4	23	81

Spare Parts

Designation	Screw	Wrench
	DCIR/L-20T04-3/4	DS M5X0.8X12-SH
DCIR/L-25T05-3/4	DS M5X0.8X16-SH	DHLW-4

Note: Available in store for testing